

GRADALL[®]
A JLG COMPANY

G6-42A

MATERIAL HANDLERS



- Rough Terrain
- All-Wheel Steering
- 6,600 lb (3,000 kg) Capacity
- 42 ft (12.8 m) Lift Height



DO NOT exceed rated lift capacity loads, as unstable and dangerous machine conditions will result.

DO NOT tip the machine forward to determine the allowable load.

DEDUCT 350 LB (159 KG) FROM ALL CAPACITIES WHEN MACHINE IS EQUIPPED WITH WINCH

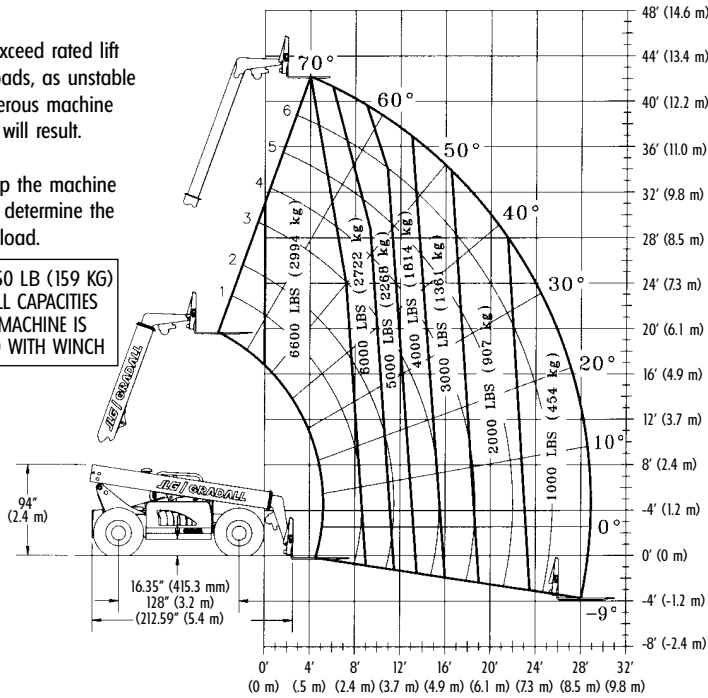

IMPORTANT

Rated lift capacities shown are with machine equipped with carriage and pallet forks. The machine must be level on a firm surface with undamaged, properly inflated tires. Machine specifications and stability are based on rated lift capacities at specific boom angles and boom lengths. [If specifications are critical, the proposed application should be discussed with your dealer.]

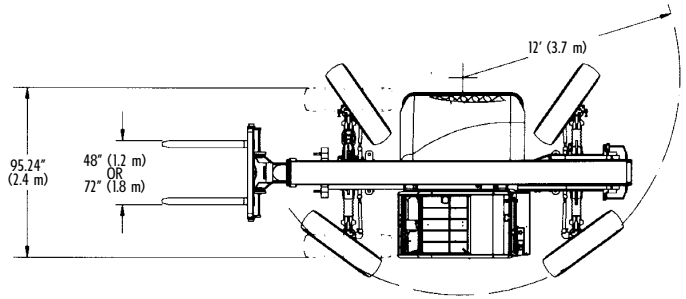

The ALL-WHEEL steer maneuverability solution efficiently managing loads up to 6,600 lbs.

The Model G6-42A by JLG and Gradall introduces a unique combination of advantages, combining all-wheel steering along with a proven record for excellent strength and reliability.

The Model G6-42A moves efficiently around jobsites, achieving the machine positioning you need to handle up to 6,600 lb loads of block, brick, lumber and other materials. But that's not all. The unique corporate marriage combining JLG and Gradall also provides superior product support capabilities and a wide variety of attachments.

- An all-wheel steering system allows the machine to maneuver through crowded areas, or effectively move into difficult-to-achieve positions, enabling operators to pick and place loads in more precise locations.
- The 80-horsepower John Deere engine is side-mounted for even weight distribution. The low-profile engine placement is designed for efficiency in performing routine service functions.
- The overlapping, three-section boom is exceptionally strong, and designed to afford a clearer operator view when the boom is moving cargo. Capacities meet and even exceed contractor's most popular expectations.
- A 42-foot lift height is standard, with an optional 6-foot vertical mast for even greater lift height. Maximum reach is 29 feet.
- The large operator compartment provides a wide view of the jobsite. The cab also has certified FOPS/ROPS operator protection and a wrap-around dashboard with easy-to-identify gauges.
- A Quick-Switch boom-end design enables the Model G6-42A to use a range of attachments with excellent strength and capacity.

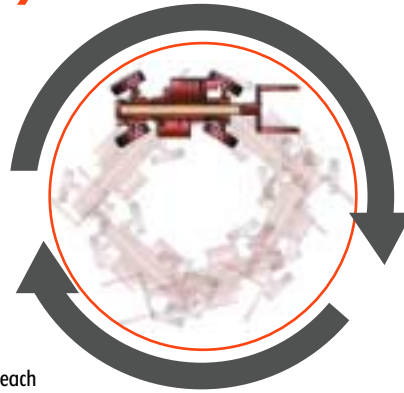

- Four-wheel drive lets the Model G6-42A move efficiently on hard surfaces as well as over sand, stones and sticky mud. Stability is enhanced with a 128-inch wheelbase, good weight distribution and low center of gravity. Less than 8 feet tall, the machine also moves through most standard doorways.

- Rough Terrain
- All-Wheel Steer
- 6,600lb (3,000l)
- 42 ft (12.8 m) Lit
- The 80-horsepower John Deere engine is enclosed in a low-profile compartment.

G6-42A MATERIAL HANDLERS

PERFORMANCE SPECIFICATIONS

RATED CAPACITY at 24" (610 mm)
Load Center 6,600 lb (3,000 kg)
MAXIMUM LIFT HEIGHT 42 ft (12.8 m)
MAXIMUM REACH 29 ft (8.8 m)
MAXIMUM CAPACITY at Maximum Lift Height
..... 6,000 lb (2,722 kg)
MAXIMUM CAPACITY at Maximum Reach
..... 1,000 lb (454 kg)
HEIGHT 94 in (2.4 m)
WIDTH 96 in (2.4 m)
WHEELBASE 128 in (3.25 m)
OUTSIDE TURNING RADIUS 12 ft (3.7 m)

TRANSMISSION Hydrodynamic
FRAME LEVELING 10 degrees
LIFT SPEED (Boom Retracted)
Empty97 f.p.m. (29.5 m/min)
Loaded94 f.p.m. (28.6 m/min)
MAXIMUM TRAVEL SPEED
Standard 80 HP with 3-Speed
..... 16 mph (25.7 km/hr)
Optional 100 HP with 4-Speed
..... 22 mph (35.4 km/hr)
DRAWBAR
PULL (Loaded) 18,000 lb (7,390 kg)
OPERATING WEIGHT 20,400 lb (9,280 kg)



- The new wrap-around dash makes it convenient to monitor critical machine functions.

OPTIONAL ACCESSORIES

TURBOCHARGED ENGINE
John Deere 4045TF150 100 HP

CAB ENCLOSURE
Lockable, split door; heater; defroster fan; washer and windshield wiper.

HEATER & DEFROSTER FAN

LIGHT GROUP
2 cab-mounted headlights, 1 backup/tail/stoptlight and rotating beacon.

AUXILIARY HYDRAULIC CIRCUIT
Required for all attachments equipped with cylinders or other hydraulic components. Consists of valves, left hand controls, hydraulic lines.

COLD WEATHER GROUP
Ether start and block heater.

RADIAL TIRES

TILT ON JOYSTICK



g Capacity Height



Choose all-wheel, crab or front-wheel steering to accommodate jobsite conditions.



Quick-Switch Attachments

Increase the return on your equipment investment with a unique Quick-Switch attachment design. Quickly and efficiently, a single operator can change from one attachment to another, keeping the Model G6-42A working continuously on many different jobs.

OPTIONAL ATTACHMENTS

- TILT CARRIAGE**48" (1.2 m)
- TILT CARRIAGE**72" (1.8 m)
- *SLOPE PILE CARRIAGE** .. .48" (1.2 m) & 72" (1.8 m)
- *DRYWALL CARRIAGE**72" (1.8 m)
- *100° SWING CARRIAGE**72" (1.8 m)
- PALLET FORKS**
2" x 4" x 48" (50.8 mm x 101.6 mm x 1.2m)
- CUBING FORKS**
2" x 2" x 48" (50.8 mm x 50.8 mm x 1.2m)
- *BOOM HEAD MOUNTED WINCH**
- *VERTICAL MAST**6' (1.8 m) QUICK-SWITCH
- *SWING MAST**6' (1.8 m)
- TRUSS BOOM**10' (3.0 m) and 15' (4.6 m)
- BUCKET**0.75 CY (.57 m³)
- BUCKET**1.25 CY (0.95 m³)
- BUCKET**102" wide-1.25 CY (0.95 m³)
- *TRUSS BOOM WITH WINCH**10' (3.0 m) and 15' (4.6 m)
- PERSONNEL WORK PLATFORM**

*Requires auxiliary hydraulics

Use only Gradall approved attachments with the proper material handler model/attachment load capacity chart displayed in the operator's cab. OSHA requires all rough terrain forklift operators to be trained according to OSHA 29 CFR 1910.178 (1).

GRADALL®

The Gradall Company
600 East Chestnut Street
Orville, Ohio 44667
(330) 339-2211/Fax: (330) 684-1029

Printed in U.S.A. Form No. 10130 12/01
Replaces Form No. 10106

DRIVE LINE SPECIFICATIONS:

ENGINE

Make and Model John Deere 4045DF150	Displacement 276 cu. in. (4.5 L)
Fuel No. 2 Diesel	Rated Speed 2500 rpm
Cycles 4	Max. Gross BHP 80 HP (60 Kw)
No. of Cylinders 4	Fuel Tank 38 gal (141 L)

ENGINE FILTERS

Two-stage dry air cleaner – centrifugal pre-cleaner with continuous dust ejector plus cleanable and replaceable dry filter element.
Visual service indicator.
Replaceable element-type fuel filter/water separator.
Full-flow replaceable-element engine oil filter.

ELECTRICAL SYSTEM

Voltage – 12V Alternator – 63 amp Battery – 810 Cold Cranking AMP at 0°F

TRANSMISSION

Dana VDT-12000 powershift with torque converter.
Neutral start switch (park brake must also be engaged to start).
Full time 4-wheel drive.
Directional and gear change control on single steering column mounted lever.

AXLES

Trunnion mounted planetary 55° steer axles.
Integral steer cylinder.
High bias limited slip differential on front axle.

SERVICE BRAKES

Inboard wet disc brakes on front axle.

PARKING BRAKES

Wet disc spring-applied hydraulic release.
Light on dash indicates when brake is on.

TIRES

Standard: 13:00x24 – 12PR, G2 type.
Optional: 13:00R24 radial tires, 15.5-25 12PR L2.

STEERING 4-WHEEL

Power steering with manual backup.
Operator selectable 4-wheel circle, 4-wheel crab, 2-wheel front.

INSTRUMENTS

Volt meter, hour meter, engine oil pressure gauge, fuel gauge, water temp. gauge.
All gauges protected by clear acrylic covers.

CONTROLS

Grouped for operator comfort and convenience.
Boom lift and crowd on single joystick.
Right-hand tilt and sway lever.
Foot throttle.

HYDRAULIC SYSTEM-IMPLEMENT

Single-section gear pump.
40 gal (151.4 L) system capacity.
8 micron filters with visual service indicator and suction strainer.
Lift, crowd, tilt and sway cylinders have holding valves to prevent dropping of load in the event of hose failure.

This machine is designed to meet specifications of ASME B56.6b-1998. It is our policy to continually improve our products. Therefore, designs, materials and specifications are subject to change without notice and without incurring any liability on units already sold. Units pictured are equipped with optional equipment. See applicable specifications and price lists for optional equipment.