

Specifications

Model	GTH™-844	
Measurements	US	Metric
Maximum lift height	43 ft 10 in	13.36 m
Maximum forward reach	28 ft 2 in	8.59 m
Reach at maximum height	2 ft 1 in	0.64 m
A Height, stowed	7 ft 10 in	2.39 m
B Length, stowed (without forks)	20 ft 3 in	6.35 m
Width	7 ft 11 in	2.41 m
C Wheelbase	11 ft 4 in	3.45 m
D Ground clearance, center	1 ft 3 in	0.38 m
E Ground clearance, axle	1 ft 5 in	0.43 m
Fork cross section	2 x 4 in	51 x 101 mm

Productivity

Maximum lift capacity	8,000 lbs	3,629 kg
Lift capacity at maximum height	6,000 lbs	2,722 kg
Lift capacity at maximum reach	2,000 lbs	907 kg
Drive speed	17 mph	27.4 km/h
Boom up/down	13/10 seconds	13/10 seconds
Boom extend/retract	14/9 seconds	14/9 seconds
Draw bar pull	21,000 lbs	9,525 kg
Turning radius, outside (4WS)	13 ft 9 in	4.19 m
Auxiliary hydraulic flow	2-15 gpm	7.57-56.8 lpm
Auxiliary hydraulic pressure	3,000 psi	207 bar
Tires, standard size	13 x 24 in, 12 ply	

Power

Power source	Deutz 3.6TCD turbo charged diesel, Tier 4 99 hp (74 kW) *
	Perkins 854E turbo charged diesel, Tier 4 99 hp (74 kW)
	Perkins 1104D turbo charged diesel, Tier 3 99 hp (74 kW) **
Electrical system	System voltage 12 volt
Alternator	Perkins 854 - 120amps, Perkins 1104 - 95amps, Deutz 3.6TCD - 95amps
Battery	1000 CCA at 0°F (-18°C)
Hydraulic tank capacity	40 gal 151 L
Hydraulic system capacity (w/tank)	50 gal 189 L
Fuel tank capacity	35 gal 132 L

Weight***

	22,600 lbs	10,251 kg
--	------------	-----------

Standards Compliance

ANSI/ITSDF B56.6, CSA B335

* Also available as Tier 3 in limited regions.
 ** Availability limited by region and country standards.
 *** Weight will vary depending on options and/or country standards.
 **** Load ratings vary depending on attachment.

Load Chart GTH™-844****

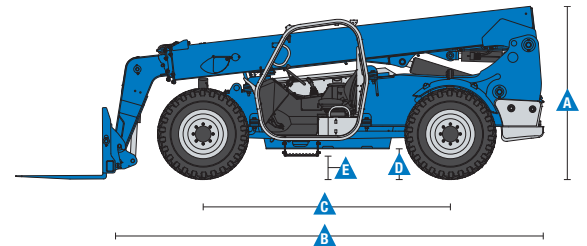
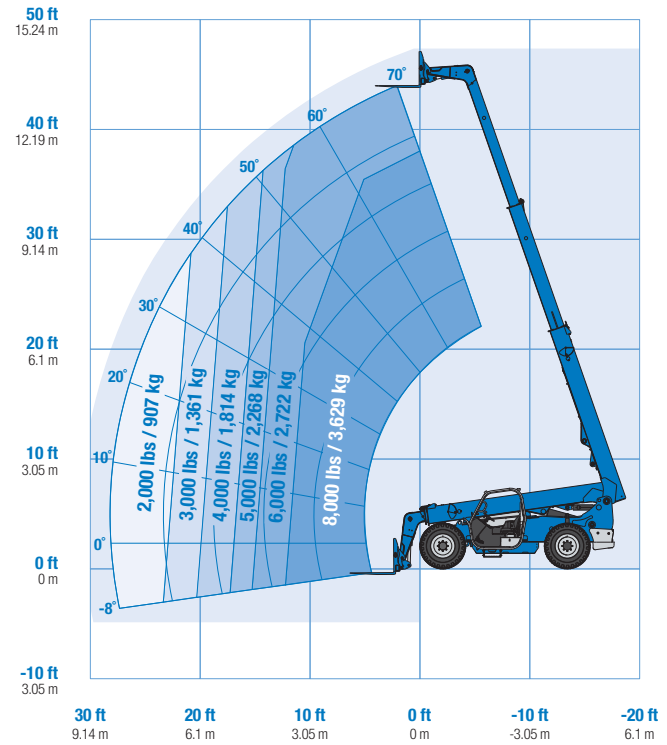

Features

Standard Features

Measurements

- 8,000 lb (3,629 kg) maximum lift capacity
- 43 ft 10 in (13.36 m) maximum lift height
- 28 ft 2 in (8.59 m) maximum reach

Productivity

- Full time 4WD
- 4WS
- Operator selectable front, crab, coordinated steering modes
- 3-speed forward and reverse powershift transmission
- Proportional frame leveling 10° each side
- Power assisted steering
- Inboard wet disc service brakes
- Wet disc spring applied parking brake
- 13 x 24 in 12-ply air filled rough terrain tires
- Front axle differential lock
- High efficiency/variable displacement hydraulic pump
- ROPS/FOPS canopy (ISO compliant)
- Single, multi-function, proportional joystick
- Machine level indicator
- Full gauge cluster with engine diagnostics
- Right-side screen standard on open cab
- Genie manual Quick-Attach™ system
- Retractable 3 in (8 cm) seatbelt
- 48 in carriage and pallet forks
- Boom angle indicator
- 10 micron hydraulic return filter
- 1,000 cold cranking amps at 0° F (-18° C)
- Reverse motion alarm
- Adjustable suspension seat
- Auxiliary hydraulic circuit (15 GPM)

Options & Accessories

Productivity

- Fully enclosed cab (includes full glass, defroster, wiper, right-side sliding window, split door, washer)
- Fully enclosed cab with air conditioning
- Dual joystick controls
- Flashing beacon
- Work lights (2 cab front mounted, 1 back-up, 1 stop/tail)
- Road lights (2 cab front mounted, 1 back-up, 2 rear stop/turn/tail)
- Fire extinguisher
- Front and top glass
- Fenders (set of 4)

Engine Options

- Deutz 3.6TCD turbo charged diesel, Tier 4i 99 hp (74 kW) *
- Perkins 854E turbo charged diesel, Tier 4i 99 hp (74 kW)
- Perkins 1104D turbo charged diesel, Tier 3 99 hp (74 kW) **
- Engine block heater

Tire Options

- 13 x 24 in 12-ply foam-filled rough terrain tires
- Firestone upgrade option

Options & Accessories

Attachment Options

- Carriages
 - 60 in (1.52 m) carriage
 - 72 in (1.83 m) carriage
 - 48 in (1.22 m) rotating carriage (10° from center left and right)
 - 60 in (1.52 m) rotating carriage (10° from center left and right)
- Forks
 - 60 in (1.52 m) pallet forks (set of two) 2 x 4 x 60 in (.05 x .10 x 1.52 m)
 - 72 in (1.83 m) pallet forks (set of two) 2 x 4 x 72 in (.05 x .10 x 1.83 m)



* Also available as Tier 3 in limited regions.

** Availability limited by region and country standards.

Genie United States

18340 NE 76th Street
P.O. Box 97030
Redmond, Washington 98073-9730
Telephone +1 (425) 881-1800
Toll Free in USA/Canada +1 (800)-536-1800
Fax +1 (425) 883-3475

Distributed By:

Effective Date: January, 2014. Product specifications and prices are subject to change without notice or obligation. The photographs and/or drawings in this document are for illustrative purposes only. Refer to the appropriate Operator's Manual for instructions on the proper use of this equipment. Failure to follow the appropriate Operator's Manual when using our equipment or to otherwise act irresponsibly may result in serious injury or death. The only warranty applicable to our equipment is the standard written warranty applicable to the particular product and sale and we make no other warranty, express or implied. Products and services listed may be trademarks, service marks or trade names of Terex Corporation and/or their subsidiaries in the USA and many other countries. Genie is a registered trademark of Terex South Dakota, Inc. © 2014 Terex Corporation.